

Aotoro®

EK 51 继电器触点输出型 Relay contact output type

INSTRUCTION MANUAL 使用说明书

PHOTOELECTRIC SENSOR
光电开关



A2302-15

Specification 规格

Model 型号	Diffuse reflective type 直接反射型	Retroreflective type 反射板反射型	Through-beam type 对射型	
	Light ON or Dark ON switch selectable 通过开关选择入光ON或遮光ON			
Free power自由电源	EK51-D50M4	EK51-D2M4	EK51-R6M4	EK51-T20ML, EK51-T20M4
Light source使用光源	Red LED 红色光源	Infrared LED 红外线	Red LED 红色光源	Infrared LED 红外线
Detecting distance探测距离	50cm (White paper白纸10x10cm)	2m (White paper白纸30x30cm)	0-6m	0-20m
Detecting target 探测物体	Transparent, Translucent, Opaque material 透明体, 半透明体, 不透明体		Opaque materials of Min.φ30mm 直径60mm以上不透明体	Opaque materials of Min.φ10mm 直径15mm以上不透明体
Hysteresis回差	Max.20% at detecting distance 不大于检测距离的20%		—	—
Power supply 电源电压	Free power type 自由电源型: AC/DC24-240V			
Power consumption消耗功率	Max.3VA			
Response time响应时间	Max.20ms			
Control output控制输出	Relay contact output:250VAC/2.5A of resistive load; Relay contact composition:1C			
Insulation resistance绝缘	Min.20MΩ(500VDC)			
Dielectric strength耐电压	1500VAC 50/60HZ for 1minute			
Ambient illumination使用环境照度	Sunlight太阳光: Max.10000lx, Incandescent lamp日光灯: Max.3000lx			
Operating temperature使用环境温度	-20 to 60°C(non-freezing condition 不结冰)			
Ambient humidity使用环境湿度	35 to 85%RH			
Protection保护结构	IP 64			
Material材质	Case: ABS, Lens: PC			
Cable配线规格	φ6mm, 5P, Length 2m长度			
Accessory 附件	Bracket托架, Bolts/nuts螺栓/螺母			

Ordering information 订购信息

EK51-D50M4-R

* I	Infrared LED(红外光)	only when customizing 仅定制时标注
	R	Red LED(红色光)
4	Light ON/Dark ON switch selectable 通过开关选择入光ON或遮光ON	
Control output 控制输出	M	Free power relay output 自由电源触点输出型
	C	DC NPN output
	B	DC PNP output
Detecting distance 检测距离	50	50cm
	2	2m
	6	6m
	20	20m
Detecting method 传感方法	D	Diffuse reflective直接反射
	R	Retro reflective反射板反射
	T	Through-beam 对射
Serial number 设计序号	51	side length 外壳边长
	EK	Relay contact output触点输出型
Photoelectric switch 光电开关	ER	Cylindrical type 圆柱型
	ED	DC univesal type 通用型
	EU	Groove shape type 槽型

Control output diagram 控制输出图

● Free power 自由电源

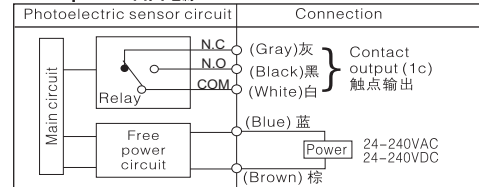

● Emitter circuit 发射器回路

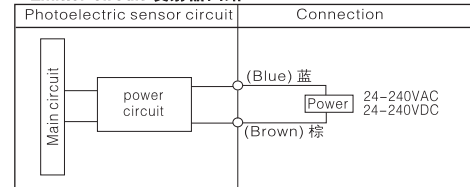

Operation mode 操作图解

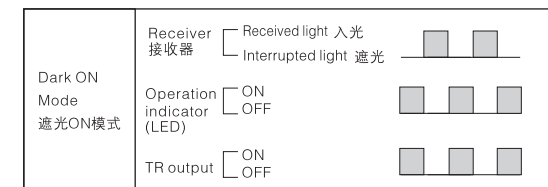
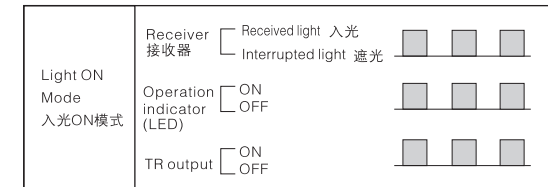

Connections 连接图

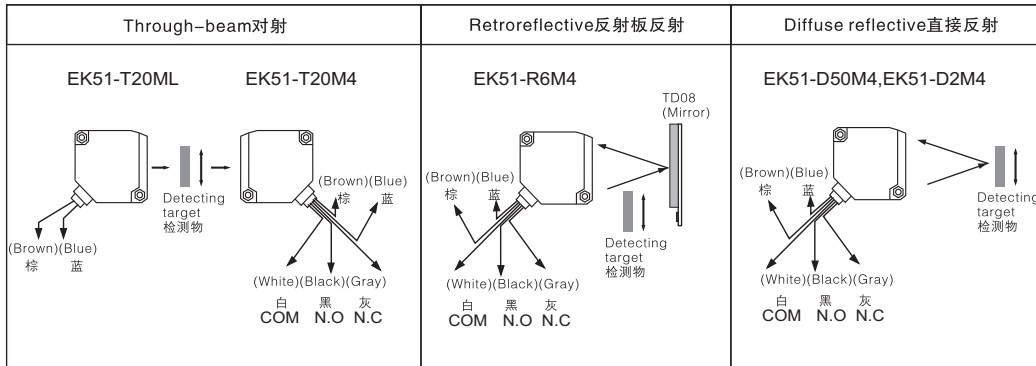

Dimensions 尺寸(unit:mm)

Product

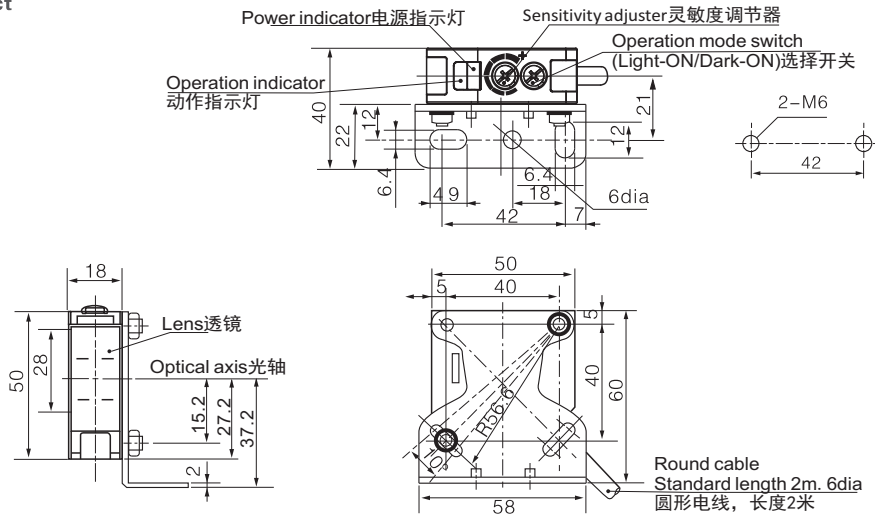

Mirror 反射板 TD08

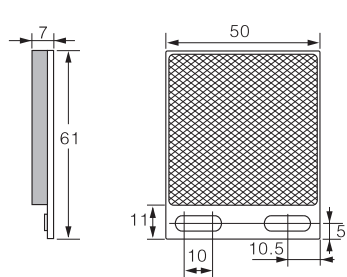

TD 03

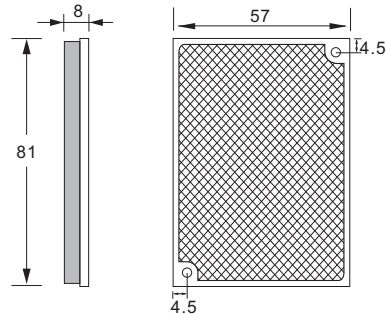

Installation and sensitivity adjustment 安装及感光度调节

Please supply the power to the sensor after installing the emitter and the receiver in face to face, and then adjust an optical axis and the sensitivity as follow; 面对面安装好发射器和接收器后请给传感器提供电源, 然后按以下说明调整光轴及感光度

Diffuse reflective type 直接反射型

- Even though the diffuse reflective type is set at max. sensitive position. The sensitivity of the sensor must be adjusted in accordance with the existence of the reflective material in background. 即使是直接反射型也要进行最大感光度的设置。传感器感光度的调节必须和反射材料的背景保持一致

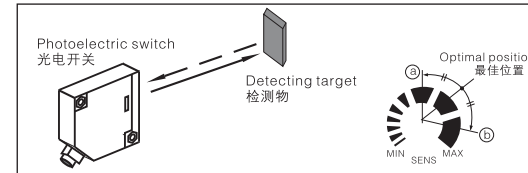

- Set the target at the area of the detecting, then turn the adjuster down to pointⒶ where the indicator just turns on from Min. position of the adjuster. 安装检测物到可检测区域, 调节旋组从最小位开始调节, 当调节到指示灯刚好亮时, 此时的旋组位置为Ⓐ点
 - Take the target out of the sensing area, then turn the adjuster until pointⒷ where the indicator turns on. If the indicator does not turn on, max. Position is pointⒸ. 从感应区域拿开检测物, 调节到指示灯亮时, 此时的旋组位置为Ⓑ, 如果指示灯一直不亮, 那么旋组的最大位置就是Ⓒ的位置
 - Set the adjuster at the center of two switching point Ⓐ, Ⓑ
 - Ⓐ, Ⓑ 两点中间位置就是最佳位
- ※ The detecting distance indicated in the specification chart is that of non-glossy white paper in the target size 200×200mm.
※ 检测物是规定的200×200mm的白色无光泽纸

Retroreflective 反射板反射

- Supply the power to the photoelectric sensor, after setting the photoelectric sensor and the mirror (TD-08) in face to face. 将发射器和反射板镜面对面安装, 并调节光轴位置和灵敏度后连接电源
- Set the photoelectric sensor in the position which indicator turns on, as adjusting the mirror or the sensor right and left, up and down. 调节反射板上下左右位置, 使传感器的指示灯变亮后固定

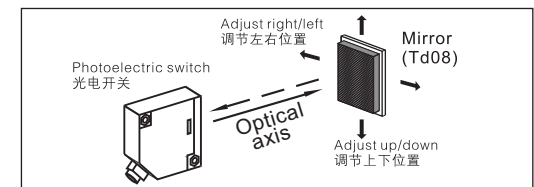

- Fix both units tightly after checking that the unit detects the target. 可靠安装两者后, 并校对使其检测到目标
- ※ If use more than 2 photoelectric sensors in parallel, the space between them should be more than 30cm. 如果并行同时使用2个以上光电传感器, 那么它们的间距应大于30cm
- ※ If reflectance of target is higher than non-glossy white paper, it might cause malfunction by reflection from the target when the target is near to photoelectric sensor. Therefore put enough space between the target and photoelectric sensor or the surface of target should be installed at an angle of 30 to 45 against optical axis. 如果被检测物体的反射率比反射板镜面的更高, 它会发生误动作。因此在传感器和被检测物体之间要留有足够的空间, 或者把被检测物体和光轴成30-45度的角度
- ※ Sensitivity adjustment: Please see the diffuse reflective type. 灵敏度调节时请参照直接反射型

Through-Beam type 对射型

- Supply the power to the photoelectric sensor, after installing the emitter and the receiver face to face. 面对面的安装好发射器及接收器后请给传感器提供电源
- Set the receiver in center of position where indicator turns on, when adjusting the receiver and the emitter right and left, up and down. 调整接收器和发射器的上下左右位置, 在指示灯亮时, 在中心位置安装好接收器
- Fix both units tightly after checking that the units detect the target. 检查检测目标后安装牢固传感器

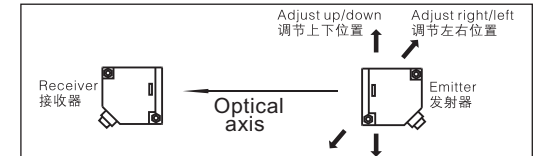

Precautions in using the product 使用注意事项

NOTE 注意

Be sure to follow the safety precautions below for adder safety

以下项目在安全确保方面非常重要, 请务必遵守。

- Do not use the sensor under the explosive or flammable gas environment. 请不要在具有可燃性、爆炸性气体的环境下使用。
- Never disassemble, repair or tamper the product. 请勿拆卸、修理、改造本产品。
- Keep the supply voltage within the specified area. 电源电压必须在额定值内。
- use the load under the specified area. 请使用额定值以下的负荷。

Caution for using 正确使用方法

- Do not use the product under the following conditions. 请不要在以下的环境中使用。

- (1) In the place of the direct sunlight. 日光直射场所。
- (2) In the place where humidity is high and condensation may occur. 湿度高或易结露场所。
- (3) In the place of the corrosive gas exists. 含腐蚀性气体场所。
- (4) In the place where vibration or shock is directly transmitted to the product. 振动或冲击能直接传送到传感器场所。

2. Connection and Mounting 连接和安装

- (1) Be sure that before giving the power, the supply voltage is less than the maximum rated supply voltage. 通电前请确认供电电源电压小于最大允许电源电压。

- (2) There are some cases where the photoelectric switch cable is unavoidably laid in a tube or duct together with a hightension or power line. This causes an induction, possibly resulting in malfunction or damage. In principal, the cable should be separately laid or shielded. 传感器导线和动力线或电力线装在同一配管中使用, 会受到干扰, 有误动作甚至被损坏。原则上传感器导线必须单独放置或者被屏蔽。

传感器导线和动力线或电力线装在同一配管中使用, 会受到干扰, 有误动作甚至被损坏。原则上传感器导线必须单独放置或者被屏蔽。

浙江欧迪龙电子科技有限公司
Zhejiang Aotero Electronic Technology CO., LTD

ADD: Liu Huang Road 2188#, Liushi town, Yueqing city, Zhejiang province. PRC 325604
浙江省乐清市柳市镇黄路2188号

TEL: 86-577-61758688 FAX: 86-577-62757002
Http://www.aotero.com E-mail: aotero@aotero.com